



Tomcat Hand and Foot Propelled Tricycles, Instructions for Use.

**UK
CA**

C E

MD



Phone Number
+44 1452 616 900



Our Website
www.tomcatuk.org

marketing@tomcatuk.org



Thank you for choosing a Tomcat™ product. We wish you many years of fun, therapy and usefulness from it.

Your Tomcat trike is a class 1 medical device it's intended purpose is to provide alleviation or compensation for a disability. When used as part of a regular exercise regime, cycling can greatly benefit the user's strength, mobility and general health and wellbeing. This user information is intended to help you get the best possible benefit from the product.

Your tricycle may be provided with special adaptations to compensate for certain issues such as reduced mobility, and when independent use of the tricycle is not possible or safe, your tricycle may be provided with special adaptations that enable a user to cycle with the assistance and supervision of a pedestrian carer.



To stay safe and get the best from your product, please read these instructions carefully.



Warning



Observe your country's highway regulation at all times.



Always wear a helmet and suitable protective clothing.



Use all safety devices provided at all times.



Do not carry passengers or allow others to ride on the rear axle or basket.



Use the park brake when mounting/dismounting or when leaving the vehicle unsupervised.



Do not ride over kerbs (except "drop kerbs") or other hazards that may damage or destabilise the vehicle.



Do not use off-road, on steep inclines, heavy cambers or sloping or uneven ground.



Any serious incident that occurs in relation to the device should be reported to the manufacturer and the competent authority of the Member State in which the user is established

Tricycle General Care and Safety.

Before Use:

- Ensure lights, reflectors, flags and warning devices are in good working order.
- Check tyre condition and maintain correct tyre pressure as printed on the tyre wall.
- Test braking and steering functions.
- Ensure all removable components (wheels, seat, divisible frame mechanisms, etc) are secure, correctly assembled in accordance with user manual instructions, interlocked where appropriate, and in good working order.

When in Use:

- Always use all safety devices provided.
- Observe the national and local laws on cycling.
- Carry a means of communication for emergency use.
- Use a secure cycle lock when leaving the tricycle unattended.

After Use:

- Clean and dry the tricycle before storing.
- Store in a dry location away from Ultraviolet (UV) light.
- Service the trike in accordance with the user handbook or after prolonged storage.

Regularly:

- Check the tyre pressure (printed on tyre wall) and tyre condition. Replace any tyres that are worn, bulging, cracked or perished.
- Check that the brakes function effectively, show no signs of wire corrosion, and are appropriately adjusted to suit the rider. For further information, refer to the manual (available online).
- Check safety devices, e.g. reflectors, lights, bell, luminous surfaces are in good condition and unobstructed.
- Visually check the chain drive lubrication. If the chain looks dry or corroded, lubricate well with cycle grease or chain lubricant.

Tricycle General Care and Safety.

Tricycle General Adjustment

Trikes with “Height Adjustable” Saddle (conventional Trike models).

- Adjust the saddle height until the fully extended leg is slightly bent at the knee.
- Adjust the backrest (if fitted) to allow the buttocks to sit on the widest part of the saddle.
- Adjust the height of the handlebars. When correct the forearms will be horizontal.
- Adjust the “reach” of the handlebars. When correct the spine will be vertical and the sightline will be horizontal.
- Adjust the gap width of lateral supports (if fitted) to closely match the body and its clothing.
- Adjust the accessories, (footshoes, harness, leg calipers, gloves, headrest, etc, etc) according to the advice of your physiotherapist/healthcare professional.

Trikes with a “Sliding Seat” (Low Sitting Trike models).

- Adjust the height of the handlebars. When correct the forearms will be horizontal.
- Adjust the backrest to a comfortable angle (If adjustable).
- Adjust the Seat Slide mechanism to a comfortable “reach”.
- Adjust the bottom Bracket and Pedals to a comfortable “reach”.
- Adjust the gap width of lateral supports (if fitted) to closely match the body and its clothing.
- Adjust the accessories, (footshoes, harness, leg calipers, gloves, headrest, etc, etc) according to the advice of your physiotherapist / healthcare professional.

Tricycle Special Features Adjustment (Where Fitted)



Note! Unless stated otherwise, refitting or locking is a reversal of removing or unlocking)

Swivelling Saddle (conventional models)

- Pull black knob (beneath saddle) down.
- Rotate saddle and release the knob. The saddle locks automatically when full rotation is reached.

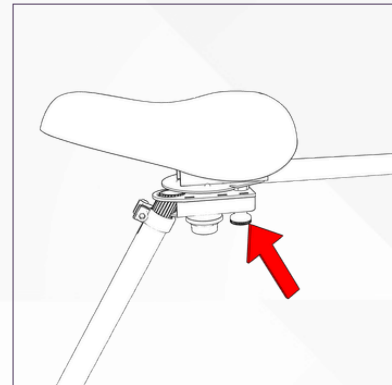

Swivelling Seat (Low sitting models).

- Press red lever down (various locations)
- Rotate seat and release the lever. The seat locks automatically when full rotation is reached.

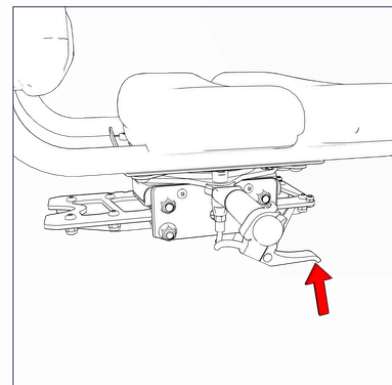

Sliding the Seat (Low sitting models).

- Undo locking nuts, adjust and relock on "standard sliding seats".
- Pull/Press button (left side of seat) adjust and release, on "Quick Adjusting" seats

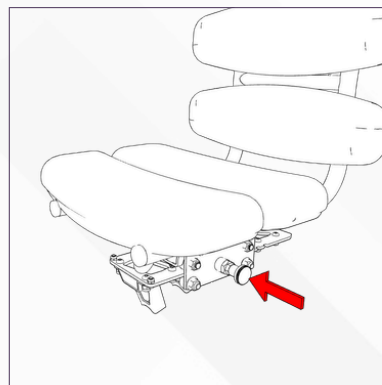
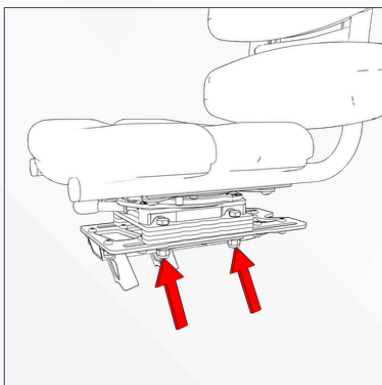

Tricycle Special Features Adjustment (Where Fitted)



Note! Unless stated otherwise, refitting or locking is a reversal of removing or unlocking)

Removing the seat (Low sitting models).

- Swivel the seat to the normal (riding) position.
- Push the black knob (beneath seat) towards the rear of the trike. (Warning! - Do not pull up or push down).
- Rotate the lever anti-clockwise.
- Lift seat to remove.

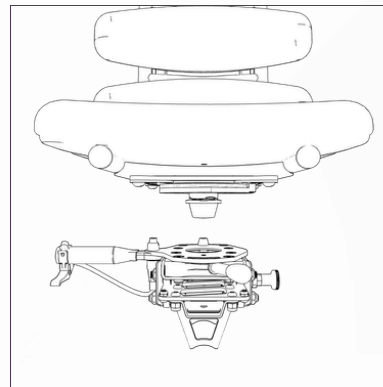
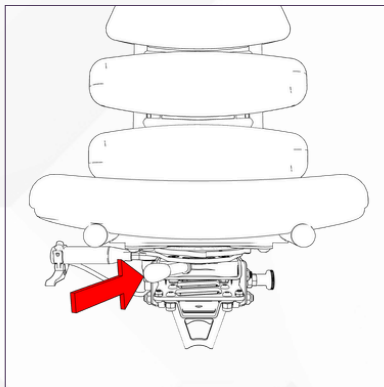

Extending/Retracting the Cranks and Pedals (Low sitting models).

- Release the Quill Clamp (1)
- Rotate the adjuster knob (2) to adjust the cranks and pedals.

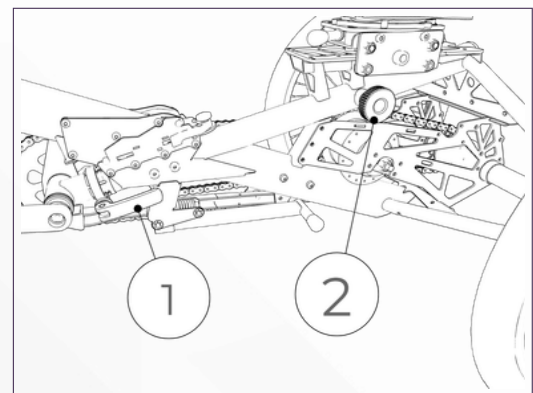

Tricycle Special Features Adjustment (Where Fitted)



Note! Unless stated otherwise, refitting or locking is a reversal of removing or unlocking)

Splitting the frame (conventional models).

- Use the left hand to support the Bottom Bracket (3) and press the interlock (4) with the left thumb.
- Open the release lever (5) fully.
- Lower the Bottom Bracket frame to the ground.
- Remove the upper frame by shifting frame backwards then lifting off.

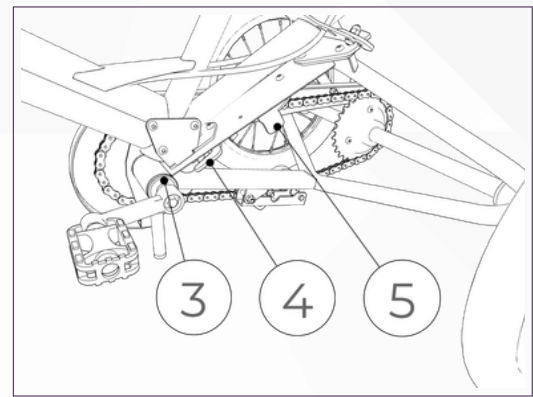

Splitting the Frame (Low Sitting models).

- Deploy the centre Stand (6)
- Lift and release the interlock button (7) whilst simultaneously rotating the Quick Release Lever (8) till it locks open.
- Remove the upper frame by lifting the front wheel until the upper frame can be moved backwards. The upper frame will then lift away.

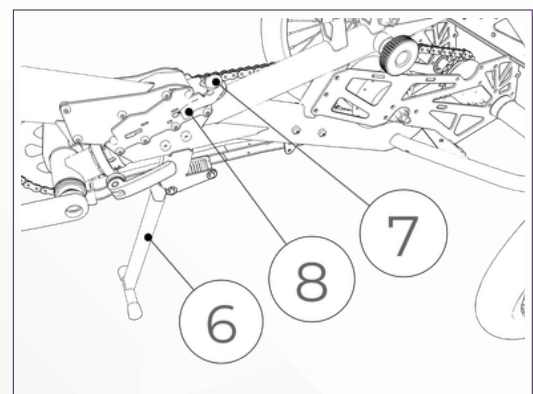

Tricycle Special Features Adjustment (Where Fitted)



Note! Unless stated otherwise, refitting or locking is a reversal of removing or unlocking)

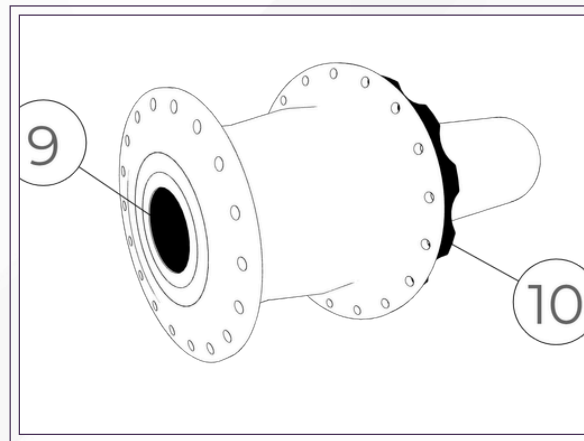

Removing "Quick Release" Rear Wheels.

- Remove the Upper frame with the lower frame supported on the stand.
- With a free hand, slightly lift the frame to lift the wheel to be removed off the ground.
- Press the Black central button (9) and remove the chosen wheel.
- Lower the frame to the ground and repeat the process for the other wheel.
- **IMPORTANT!** Always fit covers to axles shaft and wheels whenever wheels are removed.

To Refit Wheels:

- Check axle and Hub are spotlessly clean!
- With free hand, hold the black grip ring (10) to prevent the axle turning
- Slide wheel over axle.
- Press black button (9) and rotate wheel till wheel slides fully into engagement.
- Black Button (9) must be flush with axel and wheel face. Test before riding off.

Tricycle Special Features Adjustment (Where Fitted)



Note! Unless stated otherwise, refitting or locking is a reversal of removing or unlocking)

Using Carer Control.

- Move Steering arm left and right to steer.
- Pull handle backwards to brake or pull backwards on removable leash to brake
- Pull backwards on Park Brake Lever (11) and trigger (12) simultaneously to apply and lock park brake.

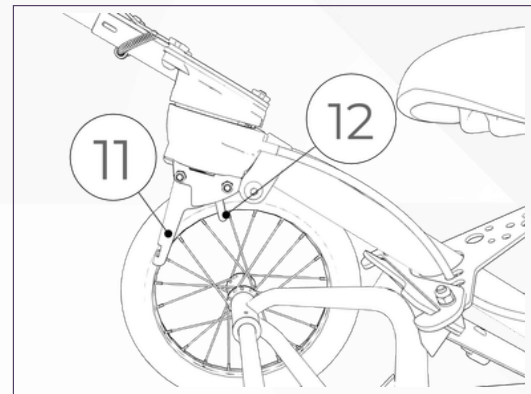

Removing Carer Control Steering arm

- Press down on release trigger
- Push arm forward and remove.

Refitting Carer Control Arm

- Fit arm "keyholes" over the three locking posts.
- Press the arm flush with the horseshoe plate and pull backwards to refit.

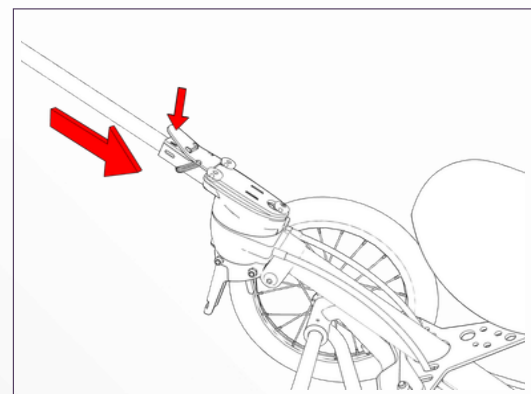

Tricycle Special Features Adjustment (Where Fitted)



Note! Unless stated otherwise, refitting or locking is a reversal of removing or unlocking)

Changing Dual Drive Axles from "fixed" to "freewheel" drive.

- Pull the knob to the left and rotate a quarter turn (conventional trikes)
- Rotate the rotary lever half a turn (Low sitting Trikes)

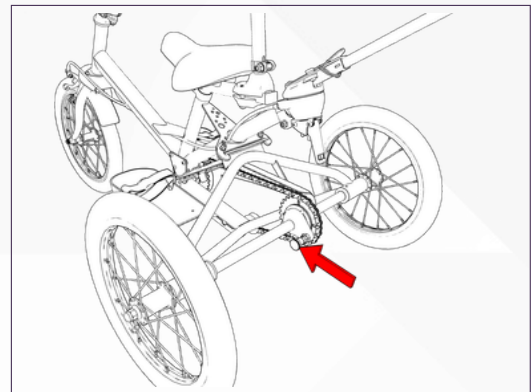

Standard Cycle Components and Consumables/Accessories/Features

Note! Brake Levers, Gear change mechanisms, indicators, lights, reflectors, cycle helmets, pedals, cables, clamps, grips, saddles, pumps, repair kits etc. are standard and familiar cycle components, well known to the cycle industry and should be used in the manner intended by the manufacturer. It you are unsure on the use or maintenance of any standard cycle component; you should seek the advice of a cycle technician before use.



For further information on how to set up and use your trike safely please visit:
www.tomcatuk.org

IFU - MANUAL TRIKES - REV3 | April 2026

Add your notes here:



.....

.....

.....

.....

.....

.....

.....

.....

.....

.....

.....

.....

Warranty



Scan QR code to view full version of warranty.



Video manuals

Tiger Manual



Fizz trike Manual



Skool Kat Manual



Roadhog Manual



Dragon Range Trike Manual



Apprentice Trike Manual



Thunderbolt & Thunderfly Manual



Rotor Trike Manual



Silver trike Manual



Bionic Buddy Manual



Electric trike Manual



Tomcat Innovations



Quick Release Seat™



Carer Control™



Smart Brake™



Two Piece Frame™



Trailer Trike™



Customisation



Pitstop™, Quick Release Rear Wheels



Dual Axle™

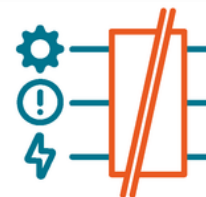

Connect™ - Tomcat "Control, Interface Technology"



Bionic Buddy™



Tomcat SNI Ltd
Unit 13/7 The Gloucester Business Park
Hucclecote, Gloucester
GL3 4AA, UK
Tel +44(0)1452 616900
Email info@tomcatuk.org
Web www.tomcatuk.org



Advena Limited.
Tower Business Centre, 2nd Flr.,
Tower Street,
Swatar, BKR 4013
Malta.
Tel +356 2546 6689
Email info@advena.mt
Web www.advena.mt

Disposal and Recycling

Tricycle: At the end of its service life, do not dispose of this vehicle in household waste. Hand it in at a municipal collection point or a specialised recycling centre. Always dispose of in accordance with local regulations.

Electronics (if applicable): This product is subject to the WEEE Directive. Electronic components and batteries must be disposed of separately. Remove the battery before disposal and take it to an authorised battery collection site.

Packaging: Protect the environment by sorting packaging materials for recycling according to your local municipal guidelines.